

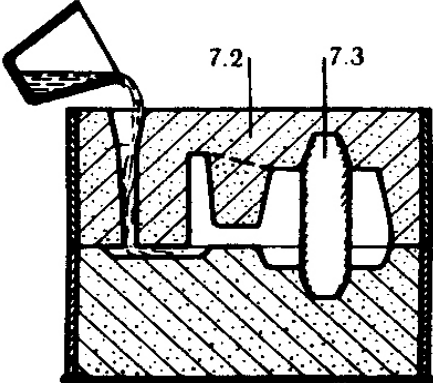

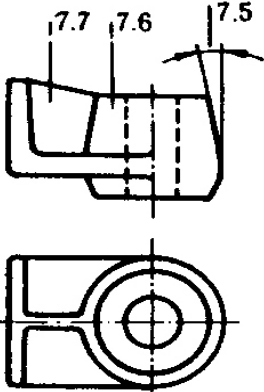
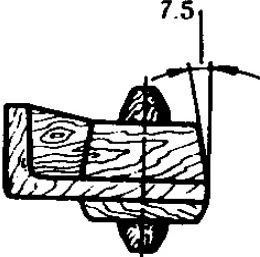

<p>7.1 casting (process) lití, odlévání</p> <p>7.2 mould forma</p> <p>7.3 core jádro</p>	
<p>7.4 casting odlitek</p> <p>7.5 draft, taper formovací úkos</p> <p>7.6 boss nálitek</p> <p>7.7 rib žebro</p>	
<p>7.8 pattern model</p>	
<p>7.9 solid pattern nedělený model</p>	
<p>7.10 split pattern dělený model</p> <p>7.11 parting plane dělicí plocha</p> <p>7.12 core print známka jádra</p>	

<p>7.13 loose-piece pattern model se snímatelnou částí</p> <p>7.14 loose-piece snímatelná část</p>	
<p>7.15 sweep pattern šablona</p>	
<p>7.16 core box jaderník</p>	
<p>7.17 running (gating) systém vtoková soustava</p> <p>7.18 pouring basin vtoková jamka</p> <p>7.19 sprue vtok</p> <p>7.20 runner vtokový kanál</p> <p>7.21 gate zářez</p>	

<p>7.22 strainer core sítko</p> <p>7.23 choke škrcení průtoku</p> <p>7.24 dirt (slag) trap, skimming chamber, skim gate struskovák</p>	
<p>7.25 parting gate vtoková soustava s vtokem v dělicí rovině</p>	
<p>7.26 top gate vrchní vtok</p>	
<p>7.27 shower gate sprchový vtok</p>	
<p>7.28 step gate etážový vtok</p>	
<p>7.29 bottom gate spodní vtok</p> <p>7.30 horn gate rohličkový vtok</p>	
<p>7.31 slit (slot) gate štěrbinový vtok</p>	

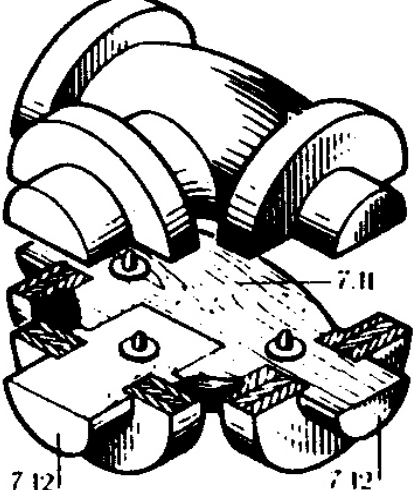
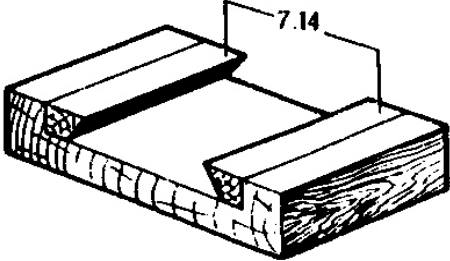
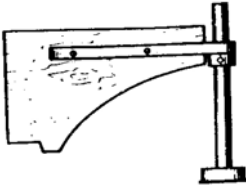
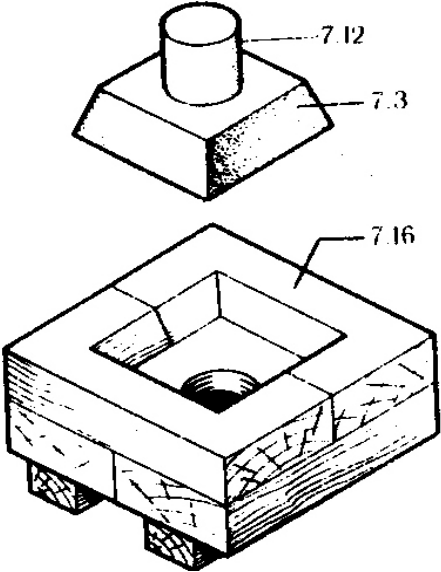
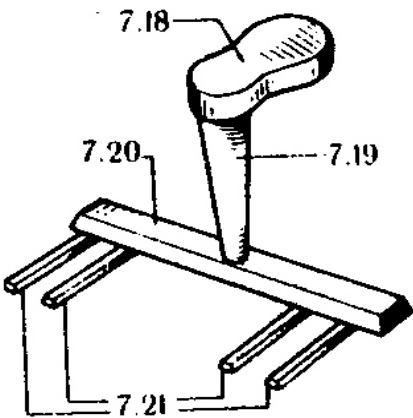
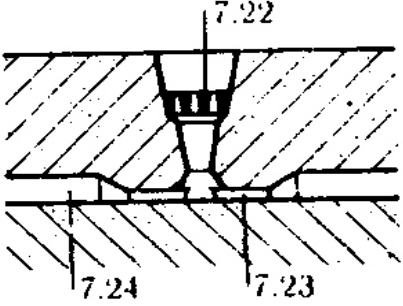
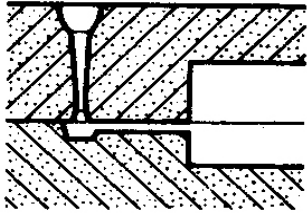
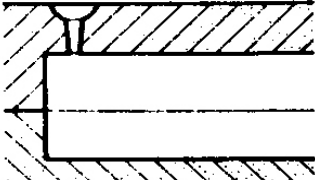
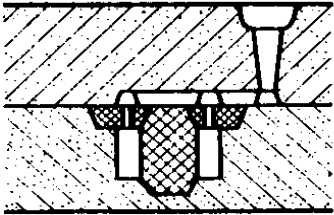
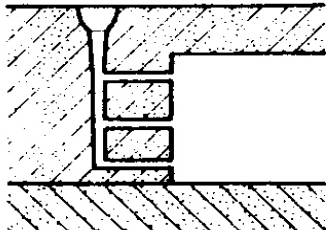
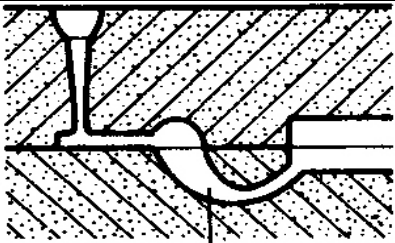
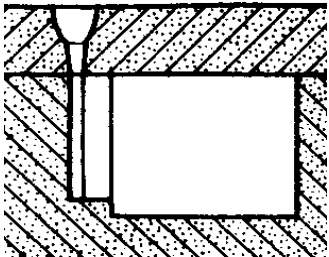
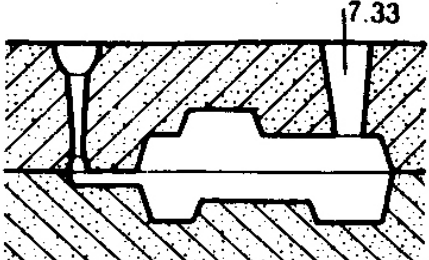
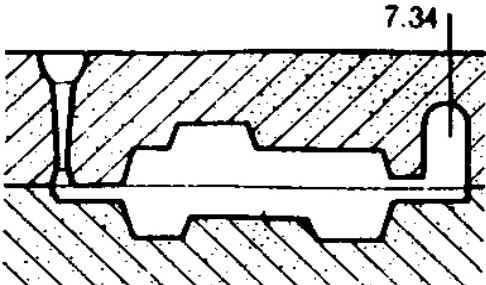
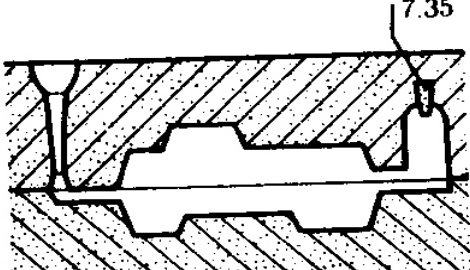
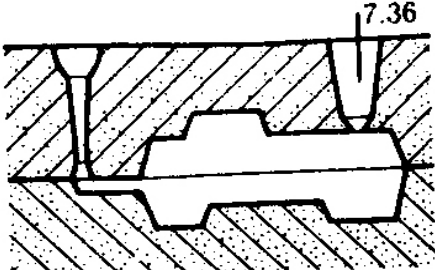
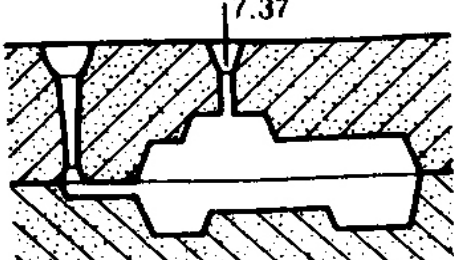
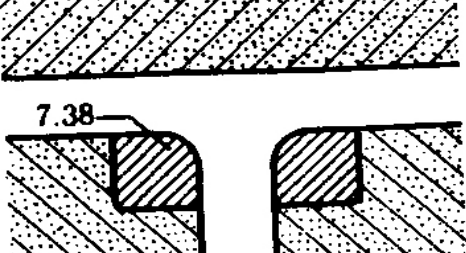
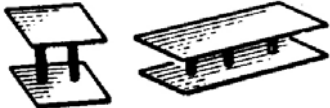
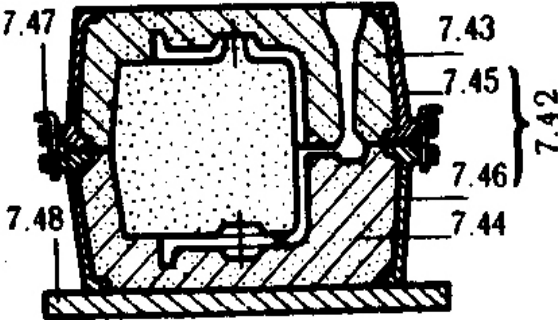
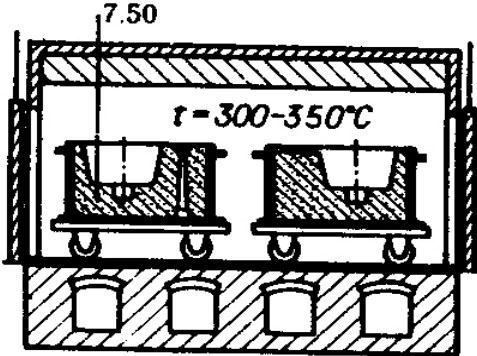
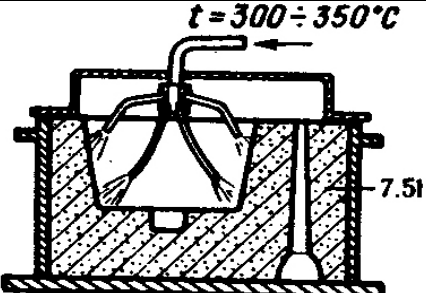
<p>7.32 feeder (head), riser nálitek</p>	
<p>7.33 open feeder (riser) otevřený nálitek</p>	
<p>7.34 blind feeder (riser) uzavřený nálitek</p>	
<p>7.35 permeable (pencil) core Williamsovo jádýrko</p>	
<p>7.36 necked down (neck-down) feeder (riser) nálitek s krčkem</p>	
<p>7.37 whistler výfuk</p>	
<p>7.38 chill, densener chladítko</p>	

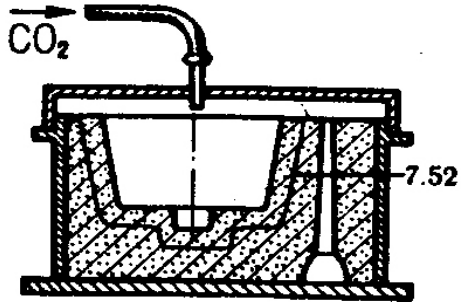
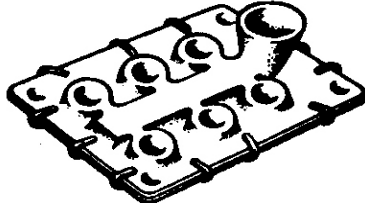
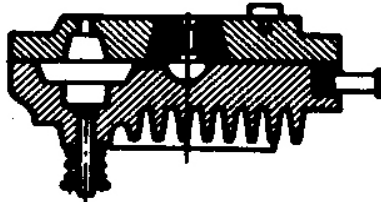
<p>7.39 chaplet podpěrka</p>	
<p>7.40 expendable mould jednorázová forma</p>	
<p>7.41 sand mould písková forma</p> <p>7.42 flask, moulding box formovací rám</p> <p>7.43 cope vršek formy</p> <p>7.44 drag spodek formy</p> <p>7.45 cope box vrchní formovací rám</p> <p>7.46 drag box spodní formovací rám</p> <p>7.47 allignment pin kolík</p> <p>7.48 bottom board (plate) modelová deska</p>	
<p>7.49 green-sand mould forma na syrovo</p>	
<p>7.50 dry-sand mould vysušená forma</p>	
<p>7.51 skin-dried mould přisušená forma</p>	

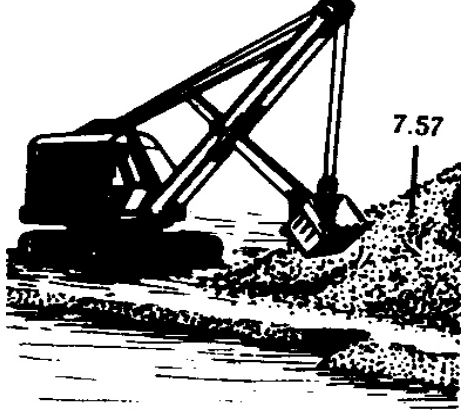
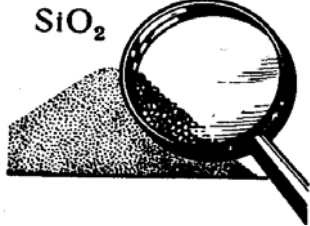
<p>7.52 carbon dioxide treated mould chemicky tvrzená forma</p>	
<p>7.53 shell mould skořepinová forma</p>	
<p>7.54 permanent mould trvalá forma</p>	
<p>7.55 metal mould kokila</p>	
<p>7.56 mould material formovací materiál</p>	
<p>7.57 natural moulding sand přírodní ostřivo</p>	
<p>7.58 silica křemen</p>	
<p>7.59 clay jíl</p>	

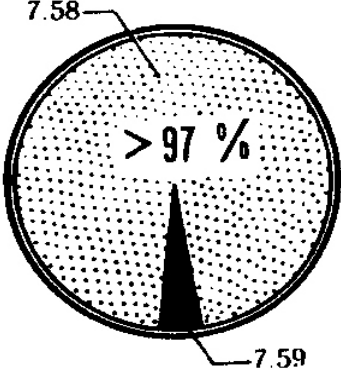
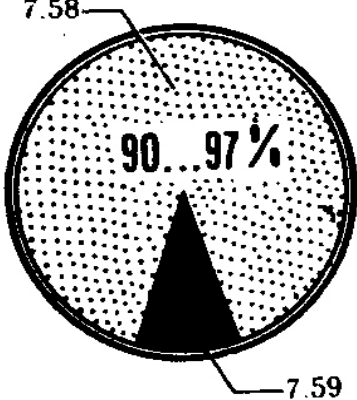
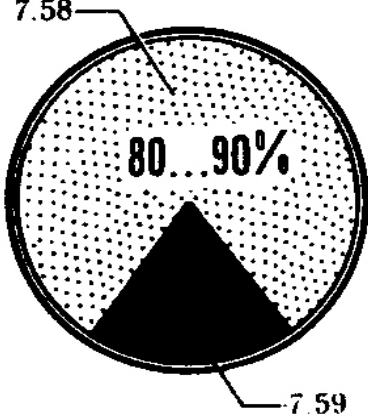
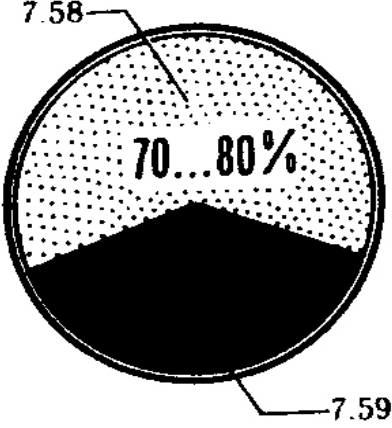
<p>7.60 high-silica sand křemenné ostřivo</p>	
<p>7.61 weak (lean) sand chudé ostřivo</p>	
<p>7.62 medium strong sand polomastné ostřivo</p>	
<p>7.63 strong sand mastné ostřivo</p>	

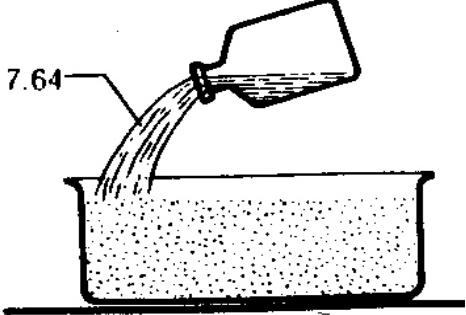
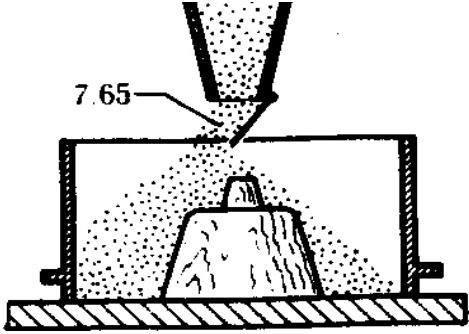
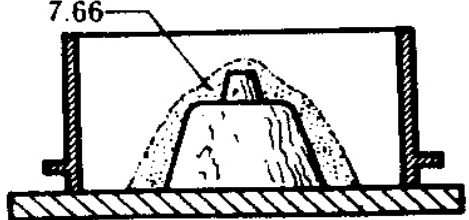
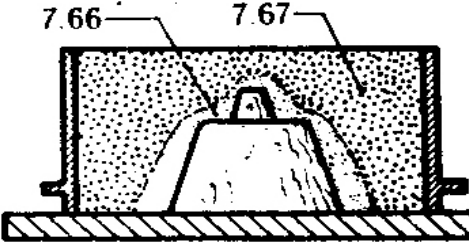
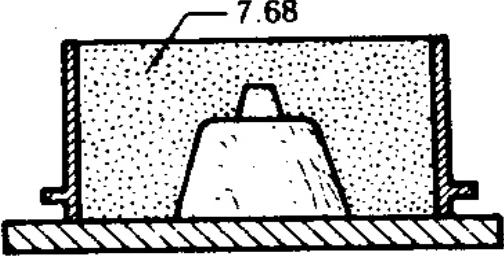
<p>7.64 binder pojivo</p>	 <p>7.64</p>
<p>7.65 moulding mixture formovací směs</p>	 <p>7.65</p>
<p>7.66 facing sand modelová směs</p>	 <p>7.66</p>
<p>7.67 backing sand výplňová směs</p>	 <p>7.66 7.67</p>
<p>7.68 facing-and-backing sand jednotná směs</p>	 <p>7.68</p>
<p>7.69 self-hardening mixture samovytvrditelná směs</p>	
<p>7.70 moulding-sand preparation příprava směsi</p>	

